



KEMENTERIAN
PENDIDIKAN
MALAYSIA
Jabatan Pendidikan Negeri Terengganu



**MODUL
PERKEMBANGAN PEMBELAJARAN
SPM 2020**

MPP 3

**FIZIK
KERTAS 1**

Nama :

Kelas :

DISEDIAKAN OLEH PANEL AKRAM NEGERI TERENGGANU

Tidak dibenarkan menyunting atau mencetak mana-mana bahagian dalam modul ini
tanpa kebenaran Pengarah Pendidikan Negeri Terengganu

MAKLUMAT UNTUK CALON

1. *Kertas soalan ini mengandungi 50 soalan.*
2. *Jawab **semua** soalan.*
3. *Jawab dengan menghitamkan ruangan yang betul pada kertas jawapan.*
4. *Bagi setiap soalan hitamkan satu ruangan sahaja.*
5. *Sekiranya anda hendak menukarkan jawapan, padamkan tanda yang telah dibuat. Kemudian hitamkan jawapan yang baru.*
6. *Rajah yang mengiringi soalan tidak dilukiskan mengikut skala kecuali dinyatakan.*
7. *Senarai rumus disediakan di halaman 3.*
8. *Anda dibenarkan menggunakan kalkulator saintifik yang tidak boleh diprogram.*

INFORMATION FOR CANDIDATES

1. *This question paper consists of 50 questions.*
2. *Answer **all** questions.*
3. *Answer each question by blackening the correct space on the answer sheet.*
4. *Blacken only **one** space for each question.*
5. *If you wish to change your answer, erase the blackened mark that you have made. Then blacken the space for the new answer.*
6. *The diagrams in the question provided are not drawn to scale unless stated.*
7. *You may use a non-programmable scientific calculator.*
8. *A list of formula is provided on page 3.*

The following information may be useful. The symbols have their usual meaning.
 Maklumat berikut mungkin berfaedah. Simbol-simbol mempunyai makna yang biasa.

$$1. a = \frac{v - u}{t}$$

$$2. s = ut + \frac{1}{2}at^2$$

$$3. v^2 = u^2 + 2as$$

$$4. \text{Momentum} = mv$$

$$5. F = ma$$

$$6. F = kx$$

$$7. \text{Gravitational potential energy} = mgh$$

$$8. \text{Kinetic energy} = \frac{1}{2}mv^2$$

$$9. \text{Elastic potential energy} = \frac{1}{2}Fx = \frac{1}{2}kx^2$$

$$10. g = 10 \text{ m s}^{-2}$$

$$11. \rho = \frac{m}{v}$$

$$12. \text{Pressure, } P = \frac{F}{A}$$

$$13. \text{Heat, } Q = mc\theta$$

$$14. \frac{pV}{T} = \text{const}$$

$$15. E = mc^2$$

$$16. v = f\lambda$$

$$17. \text{Power, } P = \frac{\text{energy}}{\text{time}}$$

$$\text{Kuasa, } P = \frac{\text{tenaga}}{\text{masa}}$$

$$18. \frac{1}{f} = \frac{1}{u} + \frac{1}{v}$$

$$19. \lambda = \frac{ax}{D}$$

$$20. n = \frac{\sin i}{\sin r}, n = \frac{1}{\sin c}$$

$$21. n = \frac{\text{real depth}}{\text{apparent depth}}$$

$$22. Q = It$$

$$23. V = IR$$

$$24. \text{Power / Kuasa, } P = IV$$

$$\text{Power / Kuasa, } P = \frac{V^2}{R}$$

$$25. \frac{N_s}{N_p} = \frac{V_s}{V_p}$$

$$26. \text{Efficiency / Kecekapan} \\ = \frac{I_s V_s}{I_p V_p} \times 100\%$$

$$27. c = 3.0 \times 10^8 \text{ m s}^{-1}$$

1. Density, speed, acceleration and electric charge are
Ketumpatan, laju, pecutan dan cas elektrik ialah
- A base quantities
kuantiti asas
 - B scalar quantities
kuantiti skalar
 - C derived quantities
kuantiti terbitan
 - D vector quantities
kuantiti vektor
2. Systematic error can be reduced by
Ralat bersistem boleh dikurangkan dengan
- A different observers
pemerhati yang berlainan
 - B make measurements at different times
membuat pengukuran pada waktu yang berbeza
 - C repeat the experiment and calculate the average value
mengulangi eksperimen dan kira nilai purata
 - D observer's eye is perpendicular to the instrument's reading scale
mata pemerhati berserenjang dengan skala bacaan alat
3. The diagram shows a flat tire of bicycles and being pumped to increase pressure in the tire.
Rajah menunjukkan satu tayar basikal yang kempis dan telah dipam untuk meningkatkan tekanan dalam tayar.

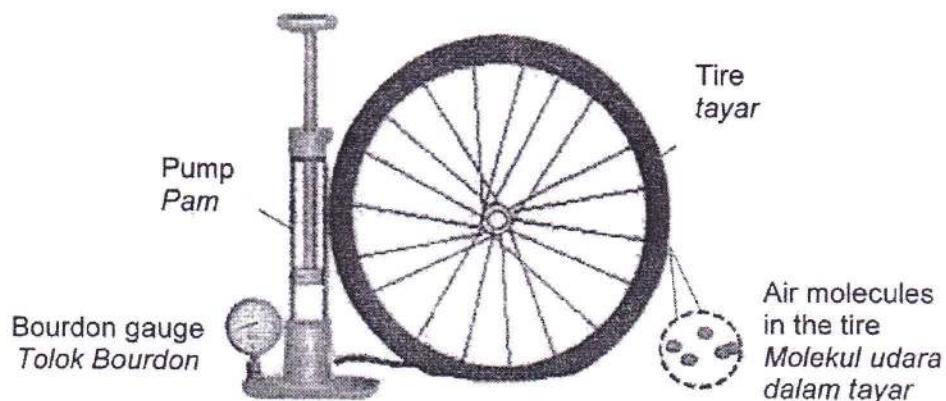

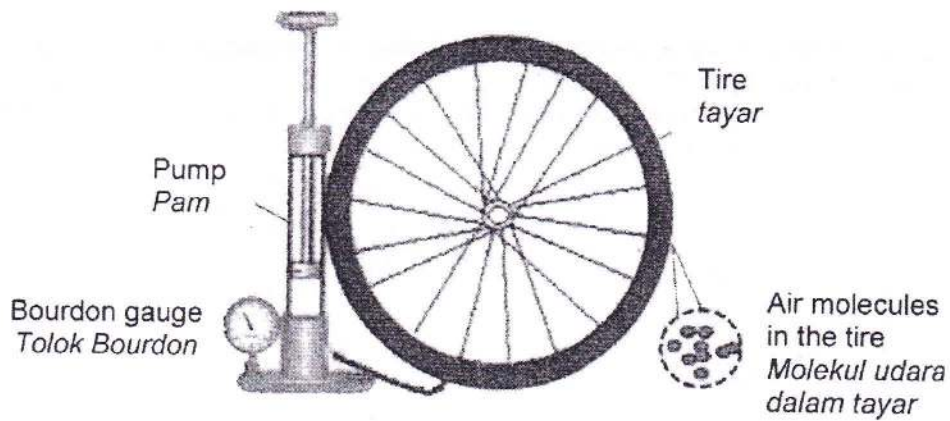

Which of the inference is correct?
Inferens manakah yang betul?

- A The pressure depends on the mass
Tekanan bergantung kepada jisim
- B The pressure depends on temperature
Tekanan bergantung kepada suhu
- C The pressure depends on the volume
Tekanan bergantung kepada isipadu
- D The pressure depends on the kinetic energy
Tekanan bergantung kepada tenaga kinetik

4. Diagram shows a boy on a swing. The boy accelerates as he moved from position A to B and decelerates as he moved from B to C.
Rajah menunjukkan seorang budak lelaki di atas buaian. Budak lelaki itu memecut ketika bergerak dari kedudukan A ke B dan dia mengalami nyahpecutan ketika bergerak dari B ke C.

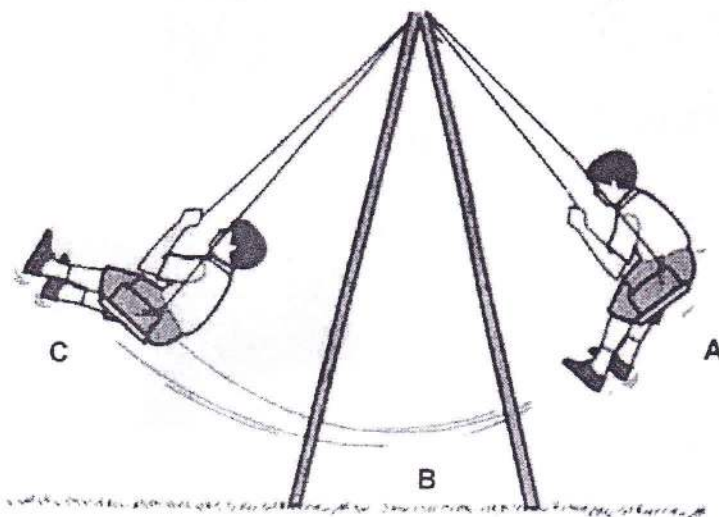

Which graph shows the correct relationship between the velocity, v , of the boy and the time, t , of the motion?

Graf manakah yang menunjukkan hubungan yang betul antara halaju, v , budak lelaki dan masa t , bagi pergerakan itu?

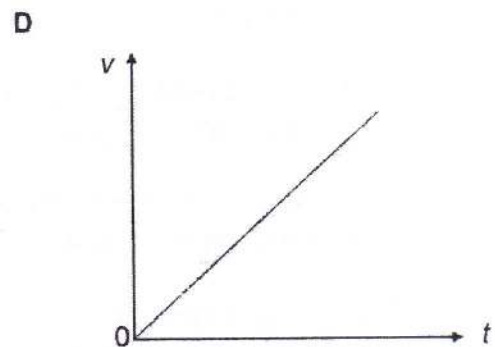
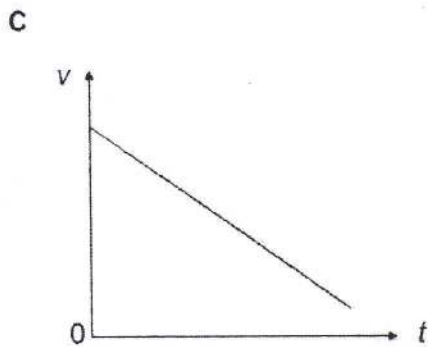
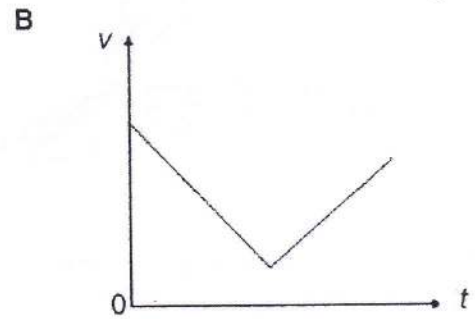
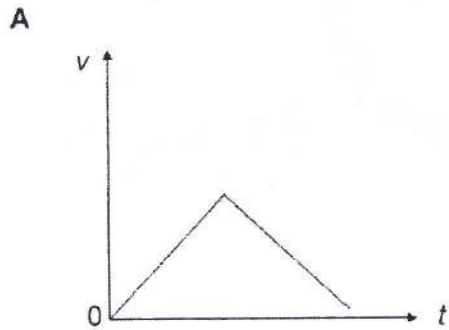

5. Which of the following situations shows the Newton's First Law of Motion?
Situasi manakah menunjukkan Hukum Gerakan Newton pertama?

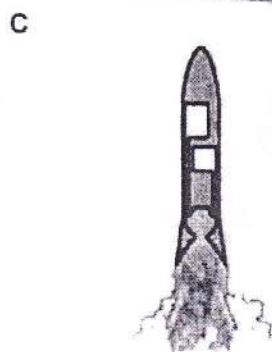
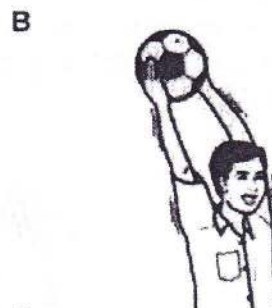

6. Diagram shows the recoil of a gun when a bullet is being fired.
Rajah menunjukkan sentakan pistol apabila peluru dilepaskan.

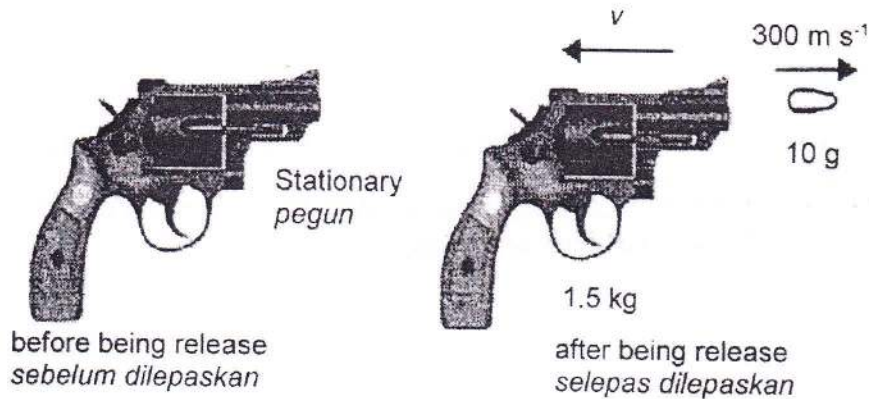

Which of the following statements is true?
Antara pernyataan berikut, yang manakah benar?

- A The collision is an elastic collision
Perlanggaran itu adalah perlanggaran kenyal
- B Both a gun and bullet do not undergo changes in momentum
Kedua-dua pistol dan peluru tidak mengalami perubahan momentum
- C The total momentum before and after the collision are the same
Jumlah momentum sebelum dan selepas perlanggaran itu adalah sama
- D The total kinetic energy before and after the collision is conserved
Jumlah tenaga kinetik sebelum dan selepas perlanggaran itu adalah terabadi
7. Diagram shows a player hits an on-coming ball with mass of 0.2 kg and velocity of 20 m s^{-1} . The ball rebounds with a velocity of 40 m s^{-1} . The time taken in the collision between the ball and the tennis racket is 0.01 s.
Rajah menunjukkan seorang pemain tenis memukul bola yang mempunyai jisim 0.2 kg yang menuju ke arahnya dengan halaju 20 m s^{-1} . Bola itu memantul dengan halaju 40 m s^{-1} . Masa yang diambil semasa perlanggaran antara bola dan raket tenis ialah 0.01 s.

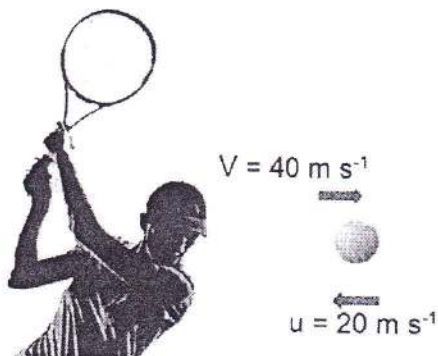

What is the impulse experienced by the ball?
 Apakah impuls yang dialami oleh bola itu?

- A 4 Ns
- B 12 Ns
- C 400 Ns
- D 1200 Ns

8. Diagram shows a photo frame of weight, $W = 20 \text{ N}$ hanging on a wall. Tension acting on both strings are T .

Rajah menunjukkan satu bingkai foto yang beratnya, $W = 20 \text{ N}$ digantung pada dinding. Tegangan yang bertindak pada kedua-dua tali ialah T .

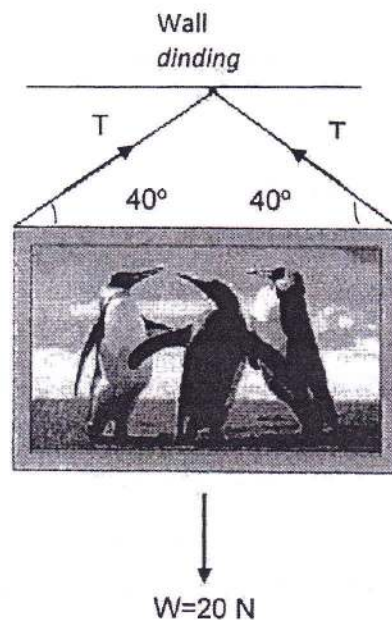

Find the tension in the string T ?
 Cari nilai tegangan tali T ?

- A 6.42 N
- B 12.9 N
- C 15.6 N
- D 31.1 N

9. Diagram shows a lift moving upwards at a constant velocity of 2 m s^{-1} .
Rajah menunjukkan lif sedang bergerak ke atas dengan halaju seragam 2 m s^{-1} .

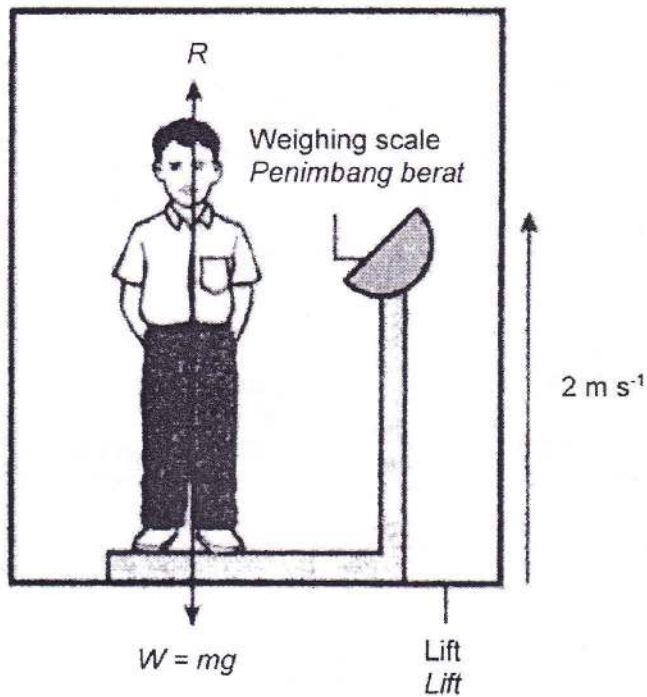

Which relationship of the forces is correct?
Hubungan antara daya-daya manakah yang betul?

- A $W > R$
 B $W = R$
 C $W < R$
10. Diagram shows a man pulling an arrow with an elastic bow.
Rajah menunjukkan seorang lelaki menarik anak panah dengan satu busur yang kenyal.

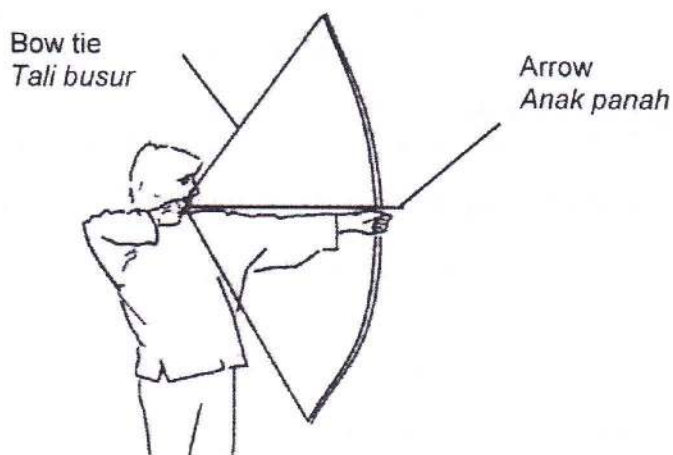

What is the change of energy that happens when he released the arrow from the bow?
Apakah perubahan tenaga yang berlaku apabila lelaki itu melepaskan anak panah dari busur?

- A Kinetic energy \longrightarrow Elastic potential energy
Tenaga kinetik \longrightarrow Tenaga keupayaan kenyal
- B kinetic energy \longrightarrow gravitational potential energy
Tenaga kinetik \longrightarrow Tenaga keupayaan graviti
- C Gravitational potential energy \longrightarrow kinetic energy
Tenaga keupayaan graviti \longrightarrow tenaga kinetik
- D Elastic potential energy \longrightarrow kinetic energy
Tenaga keupayaan kenyal \longrightarrow tenaga kinetik

11. Diagram shows a man carried a few of the same durians in the two plastic bag. But plastic bags in the diagram (b) is placed with old newspapers in it before putting the durian in.

Rajah menunjukkan seorang lelaki membawa beberapa biji durian yang sama di dalam dua beg plastik. Tetapi beg plastik dalam rajah (b) diletakkan beberapa surat khabar lama di dalamnya sebelum dimasukkan durian.

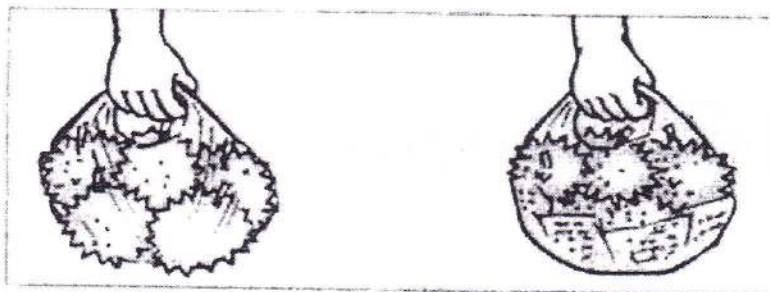

(a)
 Plastic bag was torn
Beg plastik terkoyak

(b)
 Plastic bag was not torn
Beg plastik tidak terkoyak

Why does the plastic bag (a) containing the durian tear more easily?
Mengapakah beg plastik (a) yang berisi durian lebih mudah koyak?

- A The mass of the durian in the plastic bag (a) is larger.
Jisim durian dalam beg plastik (a) adalah lebih besar.
- B The force exerted by the durian in the plastic bag (a) is larger.
Daya yang dikenakan oleh durian dalam beg plastik (a) lebih besar.
- C The pressure exerted by the durian in the plastic bag (a) on the plastic bag is larger.
Tekanan yang dikenakan oleh durian dalam beg plastik (a) terhadap beg plastik lebih besar.
- D The surface area of the durian that is in contact with the plastic bag in the plastic bag (a) is larger.
Luas permukaan durian yang bersentuhan dengan beg plastik dalam beg plastik (a) lebih besar.

12. Diagram shows a condensed milk is poured out from a can that has a hole at the top to a cup.
Rajah menunjukkan susu pekat dituang dari tin yang hanya mempunyai satu lubang pada bahagian atas tin ke cawan.

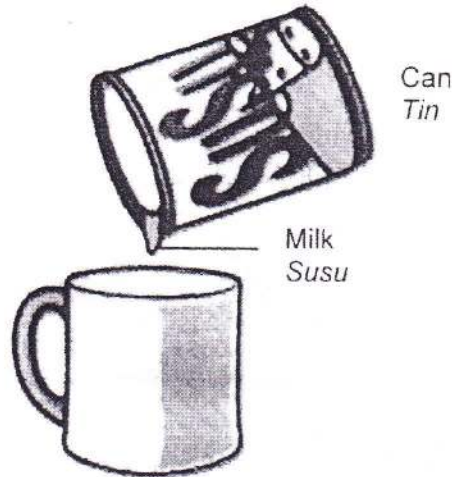

The milk does not flow out easily from the can because...
Susu tidak dapat mengalir keluar dengan mudah dari tin kerana...

- A the atmospheric pressure is low
tekanan atmosfera adalah rendah
 - B the pressure in the can is high
tekanan dalam tin adalah tinggi
 - C The pressure in the can is lower when volume of milk is low
tekanan dalam tin lebih rendah apabila isipadu susu berkurang
 - D the air pressure in the can is less than the atmospheric pressure
tekanan udara dalam tin lebih rendah berbanding dengan tekanan atmosfera
13. Diagram shows a U-tube manometer connected to a gas tank whose valve is then turned on. It is found that the gas is trapped in a U-tube. The length of the mercury column is 5 cm
Rajah menunjukkan satu tiub-U manometer disambungkan kepada satu tangki gas yang kemudian dibuka injapnya. Didapati gas terperangkap dalam tiub-U. Panjang turus merkuri ialah 5 cm

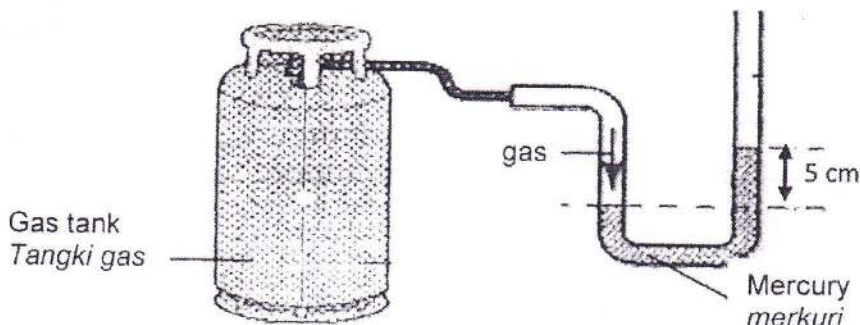

Determine the pressure of the gas in the tank.

Tentukan tekanan gas dalam silinder itu.

[Density of mercury = $13\,600\text{ kg m}^{-3}$, atmospheric pressure = $1.02 \times 10^5\text{ Pa}$]

[Ketumpatan merkuri = $13\,600\text{ kg m}^{-3}$, tekanan atmosfera = $1.02 \times 10^5\text{ Pa}$]

- A 68000 Pa
- B 108800 Pa
- C 680000 Pa
- D 782000 Pa

14. Diagram shows a boy in a raft.
Rajah menunjukkan seorang budak di atas rakit.

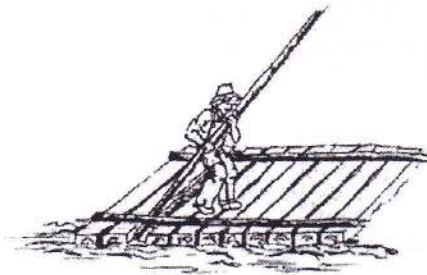

If the weight of the boy and the raft is 1200 N, what is the volume of the raft which is submerged?

Jika berat budak dan rakitnya ialah 1200 N, berapakah isipadu bahagian rakit yang tenggelam?

[Density of water = 1000 kg m^{-3}]

[Ketumpatan air = 1000 kg m^{-3}]

- A 0.12 m^3
- B 0.83 m^3
- C 1.20 m^3
- D 8.33 m^3

15. Which diagram shows the correct liquid level in the U-tube?
Rajah manakah menunjukkan aras cecair yang betul di dalam tiub-U?

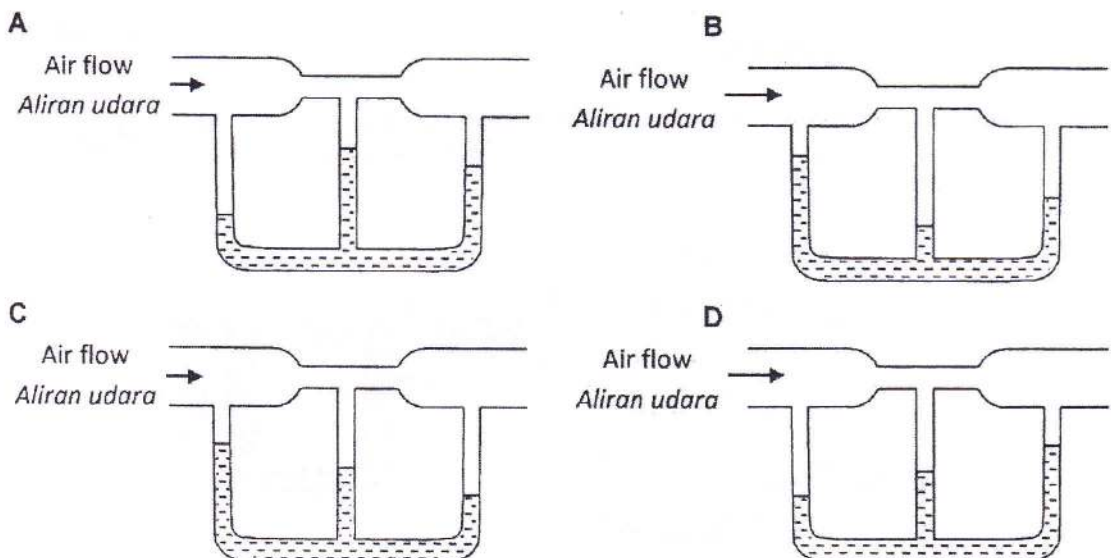

16. Which of the following functions by using Pascal's principle?
 Manakah di antara berikut berfungsi menggunakan prinsip Pascal?



Hydraulic jack / Jek hidraulik



Vacuum cleaner / Pembersih hampagas



Plunger / Pelocok

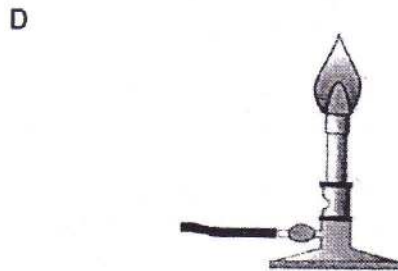

Bunsen burner / Penunu bunsen

17. Diagram shows P is in thermal equilibrium with Q and Q is in thermal equilibrium with R.
 Rajah menunjukkan P adalah dalam keseimbangan terma dengan Q dan Q adalah dalam keseimbangan terma dengan R.

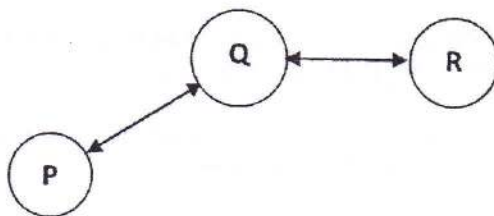

If the temperature of P is θ_P and the temperature of R is θ_R , which of the following statements is correct?

Jika suhu P adalah θ_P dan suhu R adalah θ_R , pernyataan berikut yang manakah adalah benar?

- A $\theta_P = \theta_R$
- B $\theta_P > \theta_R$
- C $\theta_P < \theta_R$

18. Diagram shows two blocks M and N of equal masses and initial temperature are being heated with the same amount of heat energy.
Rajah menunjukkan dua blok M dan N yang sama jisim dan suhu awal sedang dipanaskan dengan jumlah tenaga haba yang sama..

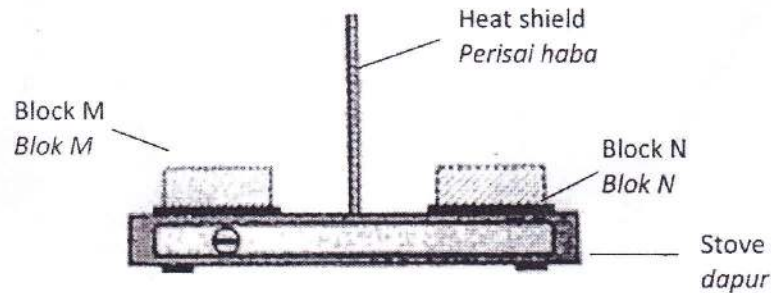

It is observed that M is hot faster than N. This observation is due to
Diperhatikan bahawa M lebih cepat panas berbanding dengan N. Pemerhatian ini adalah disebabkan oleh

- A density M < density N
ketumpatan M < ketumpatan N
- B density M > density N
ketumpatan M > ketumpatan N
- C specific heat capacity M < specific heat capacity N
muatan haba tentu M < muatan haba tentu N
- D specific heat capacity M > specific heat capacity N
muatan haba tentu M > muatan haba tentu N
19. The latent heat of fusion of a substance is the quantity of heat required to
Haba pendam pelakuran bagi sesuatu bahan ialah kuantiti haba yang diperlukan untuk
- A separate the molecules in the solid substance so that they are free to move.
memisahkan molekul dalam pepejal supaya bebas bergerak
- B increase the kinetic energy of the molecules in the solid substance.
meningkatkan tenaga kinetik molekul dalam pepejal
- C increase the temperature of the substance
meningkatkan suhu bahan
20. The air pressure in the tyre of a car is 210 kPa at an initial temperature of 25 °C. After a long journey the air temperature has increased to 35 °C. What is the air pressure in the tyre after the journey?
Tekanan udara di dalam tayar sebuah kereta ialah 210 kPa pada suhu awal 25 °C. Selepas suatu perjalanan yang jauh suhu udara itu meningkat kepada 35 °C. Berapakah tekanan udara di dalam tayar selepas perjalanan tersebut ?
- A 150 kPa
 B 217 kPa
 C 294 kPa
 D 437 kPa

21. Which phenomenon produces an image on a plane mirror?
Fenomena apakah yang menghasilkan imej di atas cermin satah?

- A Reflection
Pantulan
 B Refraction
Pembiasan
 C Diffraction
Pembelauan
 D Interference
Interferens

22. Diagram shows the path of light travelling from a glass block to air
Rajah menunjukkan satu lintasan cahaya yang merambat melalui satu blok kaca ke udara.

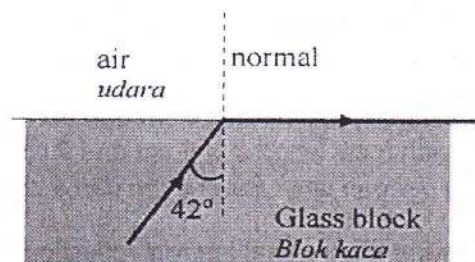

The refractive index of the glass block is
 Indeks biasan bagi blok kaca ialah

- A $\frac{1}{\sin 42}$
 B $\frac{\sin 42}{\sin 90}$
 C $\frac{1}{\sin 48}$
 D $\frac{\sin 48}{\sin 90}$
23. Diagram shows an object placed at a distance, x from a convex lens with a focal length, f .
Rajah menunjukkan satu objek diletakkan pada jarak x dari kanta cembung dengan panjang fokus, f .

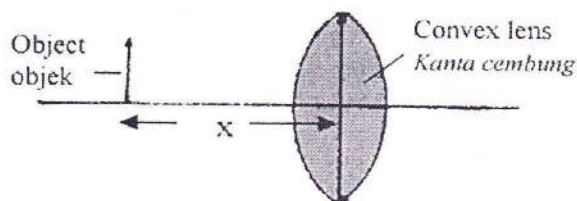

Diagram
Rajah

The image formed is **virtual** and **enlarged**. The object is at
Imej yang terbentuk adalah maya dan diperbesarkan. Objek itu berada di

- A $x > 2f$
- B $x = 2f$
- C $x < f$
- D $f < x < 2f$

24. Which of the following pairs of lenses can be used to construct a telescope?
Manakah di antara pasangan kanta berikut boleh digunakan untuk membina teleskop?

- A Two concave lenses with focal lengths of 6cm and 9 cm.
Dua kanta cekung dengan jarak fokus 6 cm dan 9 cm
- B Two convex lenses with focal lengths of 10 cm and 80 cm.
Dua kanta cembung dengan jarak fokus 10 cm dan 80 cm
- C Two concave lenses with focal lengths of 10 cm and 80 cm.
Dua kanta cekung dengan jarak fokus 10 cm dan 80 cm
- D Two convex lenses with focal lengths of 6 cm and 9 cm.
Dua kanta cembung dengan jarak fokus 6 cm dan 9 cm

25. Which diagram of the following shows total internal reflection?
Antara rajah berikut yang manakah menunjukkan pantulan dalam penuh?

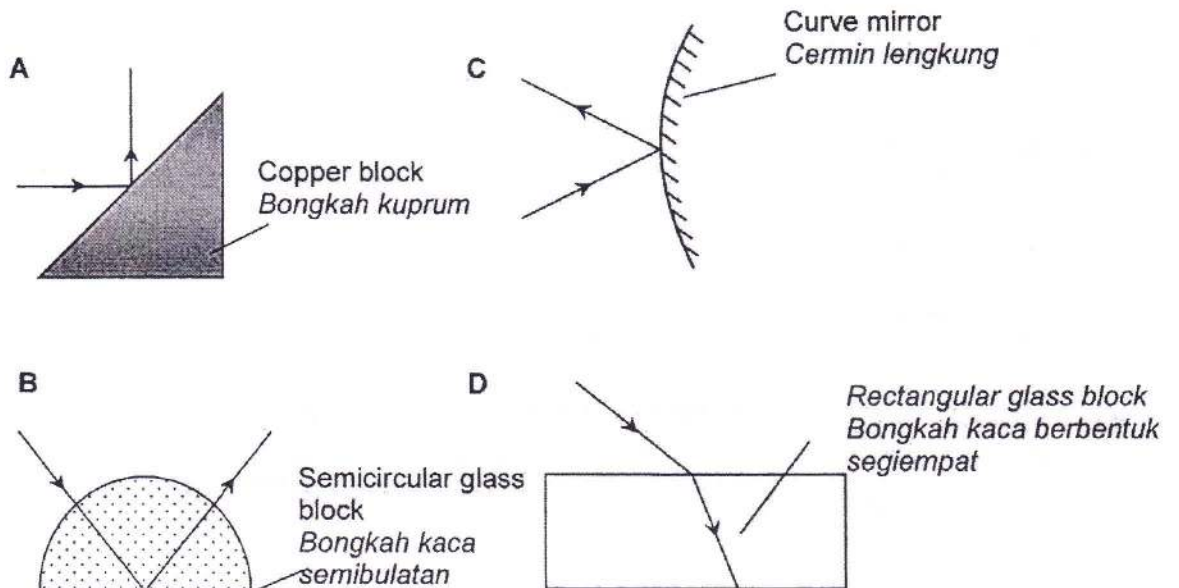

26. Diagram shows an oscillating system.
Rajah menunjukkan satu sistem ayunan

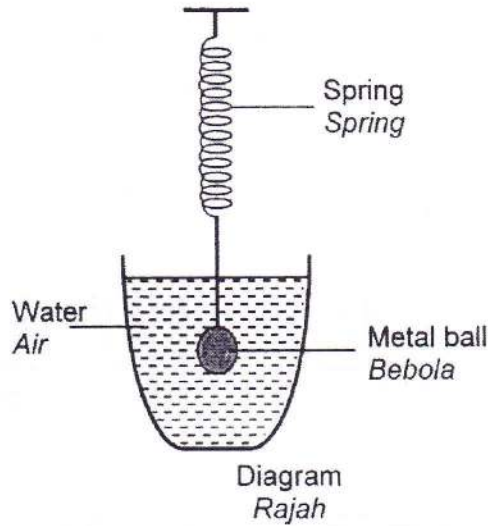

Which graph shows the correct relationship between displacement and time for the oscillating system?
Graf manakah yang menunjukkan hubungan yang betul antara sesaran dan masa bagi sistem ayunan itu?

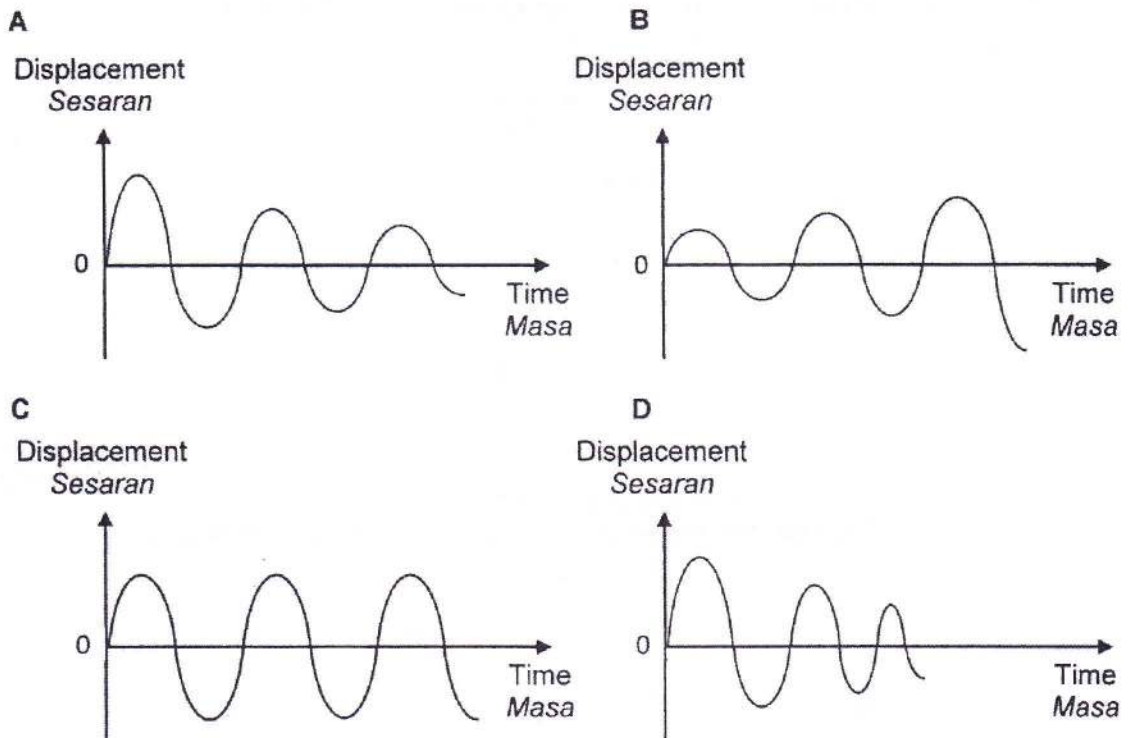

27. Diagram shows the layers of air when waves are produced by a vibrating tuning fork.
Rajah menunjukkan lapisan-lapisan udara apabila gelombang dihasilkan oleh sebuah tala bunyi.

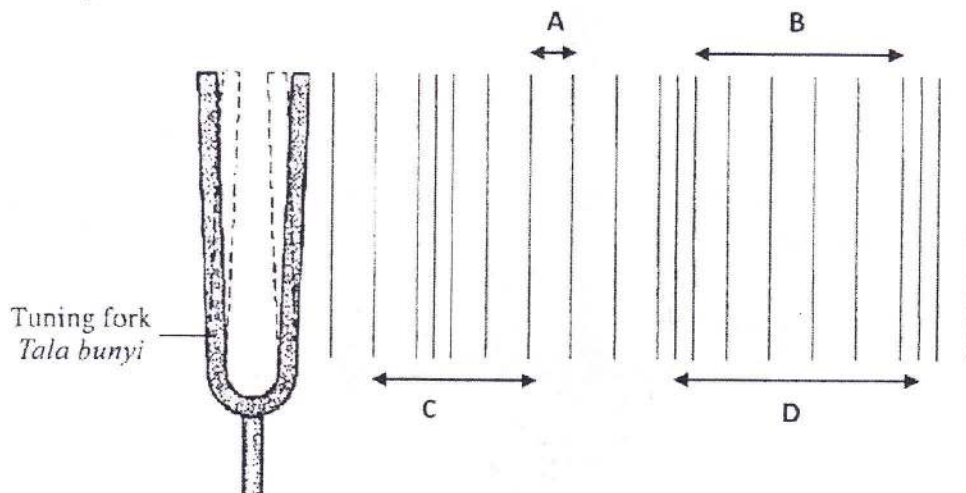

Which distance represents one wavelength?
Jarak yang manakah mewakili satu panjang gelombang?

28. Diagram shows a stone dropped into a lake with the depth of water increasing towards the centre of the lake.
Rajah menunjukkan sebiji batu dijatuhkan ke dalam tasik yang kedalaman semakin bertambah ke arah tengah tasik.

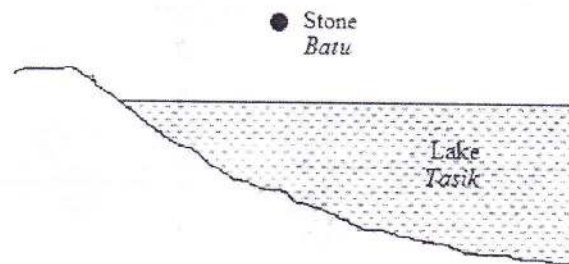
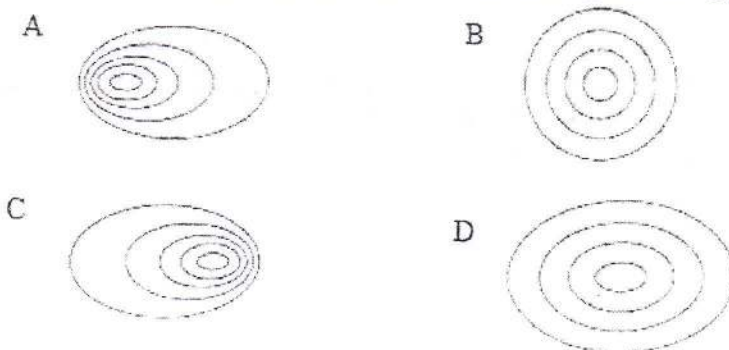
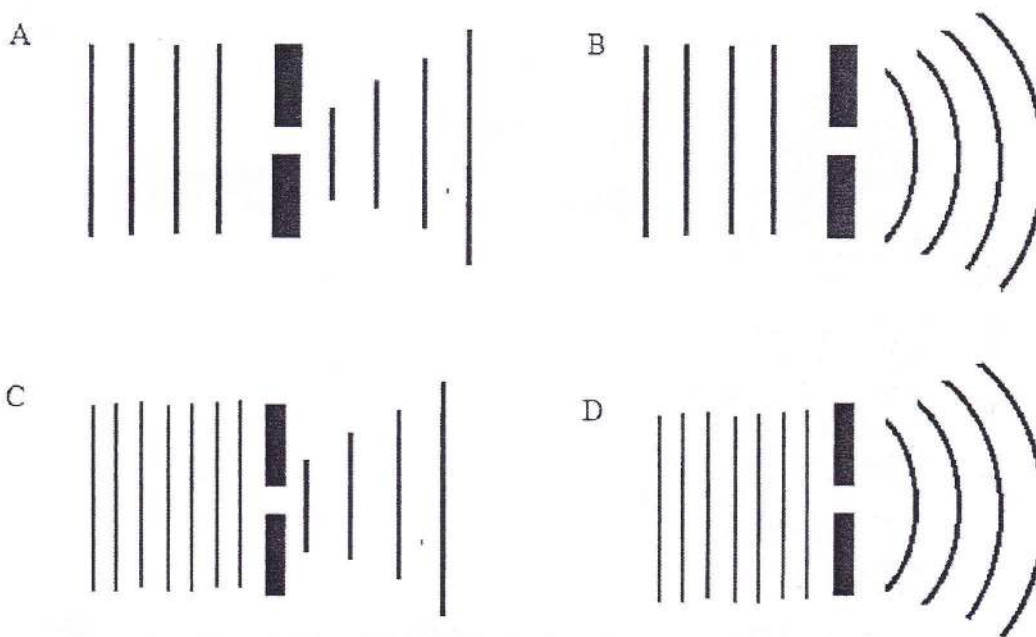

Diagram
 Rajah

Which of the following is the wave pattern formed?
Antara yang berikut, yang manakah adalah corak gelombang yang dihasilkan?



29. Which diagram shows the correct wave pattern when plane water wave pass through a gap?
 Rajah manakah menunjukkan corak gelombang yang betul apabila gelombang air berbentuk satah melalui suatu celah?



30. Which of the following electromagnetic waves has the lowest frequency?
 Antara yang berikut, gelombang elektromagnet yang manakah mempunyai frekuensi yang paling rendah?
- A Microwaves
Gelombang mikro
 - B Ultra violet rays
Sinar ultra ungu
 - C Blue light
Cahaya biru
 - D X-rays
Sinar-X
31. A light bulb is labelled 240 V, 0.25 A.
 What is the quantity of charge that flows through the bulb when it lights up at normal brightness for 10 minutes?
 Sebuah mentol lampu dilabel 240 V, 0.25 A.
 Berapakah kuantiti cas yang mengalir melalui mentol itu apabila mentol itu menyala pada kecerahan normal selama 10 minit?
- A 150 C
 - B 360 C
 - C 840 C
 - D 2400 C

32. Diagram shows two resistors connected in parallel.
Rajah menunjukkan dua perintang disambung selari.

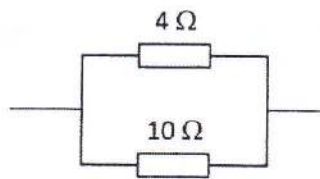

Diagram
Rajah

The effective resistance is
Rintangan berkesan adalah

- A smaller than 4Ω
lebih kecil daripada 4Ω
- B between 4Ω and 10Ω
di antara 4Ω dan 10Ω
- C between 10Ω and 14Ω
di antara 10Ω dan 14Ω
- D bigger than 14Ω
lebih besar daripada 14Ω
33. Diagram shows a cell which has internal resistance connected to a light bulb.
Rajah menunjukkan sebuah sel yang mempunyai rintangan dalam disambung kepada sebuah mentol.

Cell with internal resistance
Sel dengan rintangan

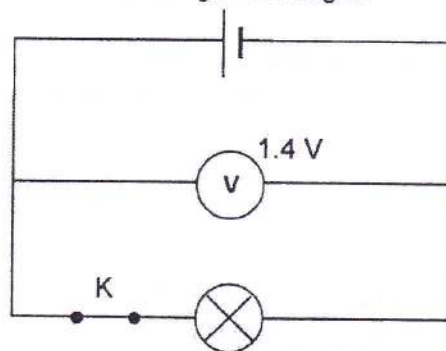

Diagram
Rajah

What is the voltmeter reading when switch K is switched off?
Apakah bacaan voltmeter apabila suis K dipadamkan?

- A 0
- B 1.4 V
- C Less than 1.4 V
Lebih kecil daripada 1.4 V
- D More than 1.4 V
Lebih besar daripada 1.4 V

34. Diagram shows an electric circuit.
Rajah menunjukkan satu litar elektrik.

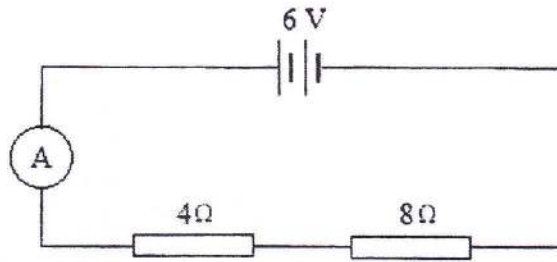

Diagram
Rajah

What is the reading of the ammeter in the circuit?
Berapakah bacaan ammeter dalam litar?

- A 0.5 A
 - B 2.0 A
 - C 3.0 A
 - D 6.0 A
35. Diagram shows the arrangement of apparatus to investigate the magnetic field produced by the current in a circular coil.
Rajah menunjukkan susunan radas untuk mengkaji medan magnet yang dihasilkan oleh arus dalam gegelung bulat.

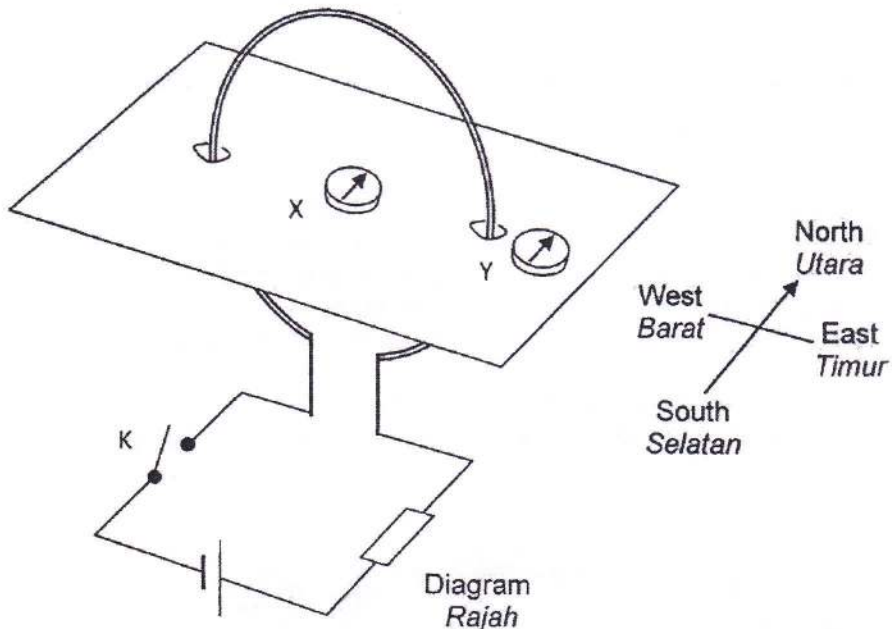

Diagram
Rajah

What are the directions shown by the pointers of compass X and compass Y when K is switched on?

Apakah arah yang akan ditunjuk oleh jarum kompas X dan Y apabila suis K dihidupkan?

	Compass X / Kompas X	Compass Y / Kompas Y
A	North / Utara	North / Utara
B	North / Utara	South / Selatan
C	South / Selatan	North / Utara
D	South / Selatan	South / Selatan

36. Diagram shows a coil WXYZ that is carrying a current.
Rajah menunjukkan sebuah gegelung WXYZ yang membawa arus.

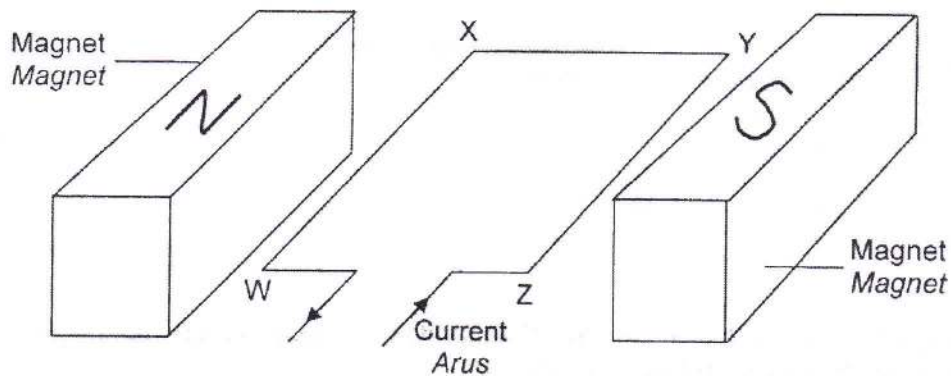

Diagram
Rajah

What are the directions of the magnetic force acting on the sides WX and YZ of the coil?

Apakah arah daya magnet yang bertindak pada sisi WX dan YZ gegelung itu?

WX		YZ	
A	Downwards / Ke bawah	Upwards / Ke atas	
B	Downwards / Ke bawah	Downwards / Ke bawah	
C	Upwards / Ke atas	Upwards / Ke atas	
D	Upwards / Ke atas	Downwards / Ke bawah	

37. Diagram shows four compasses placed near a solenoid.
Rajah menunjukkan empat buah kompas diletakkan berhampiran dengan suatu solenoid.

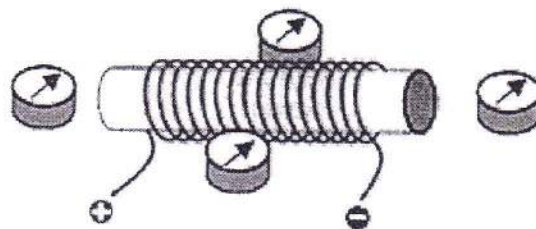
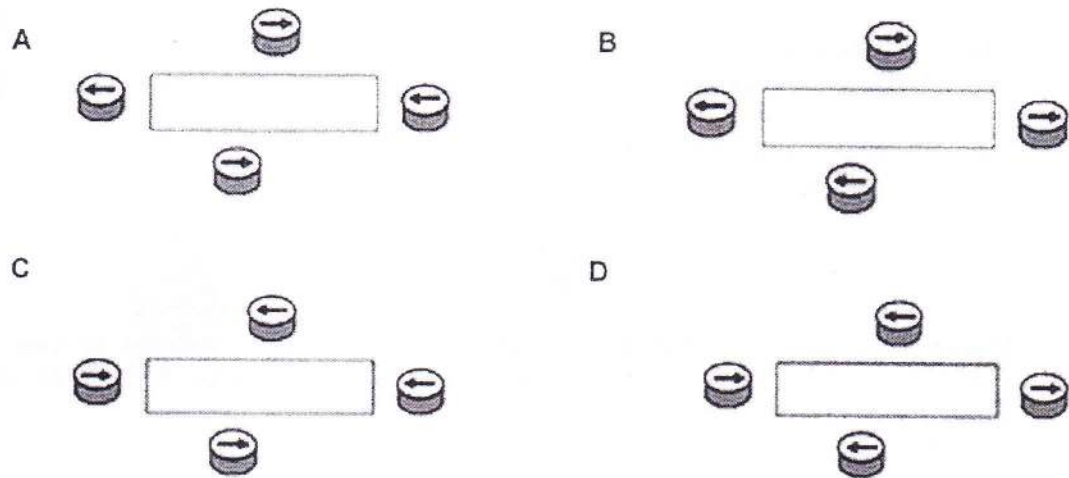

Diagram
Rajah

Which of the following shows the correct direction of the plotting compasses when the current flows through the solenoid?

Yang manakah antara berikut menunjukkan arah pesongan kompas yang betul apabila arus mengalir melalui solenoid?



38. Diagram shows a student holding a copper rod in a magnetic field.
 Rajah menunjukkan seorang pelajar memegang sebatang rod kuprum dalam suatu medan magnet.

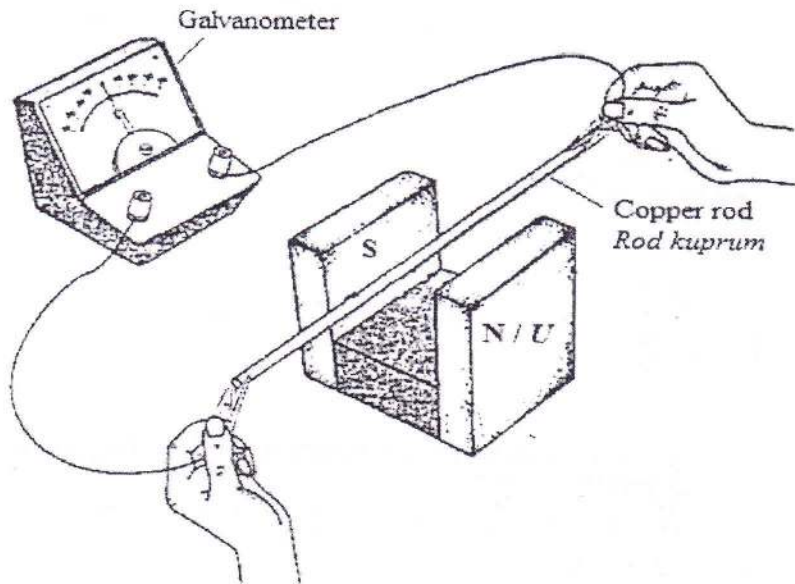
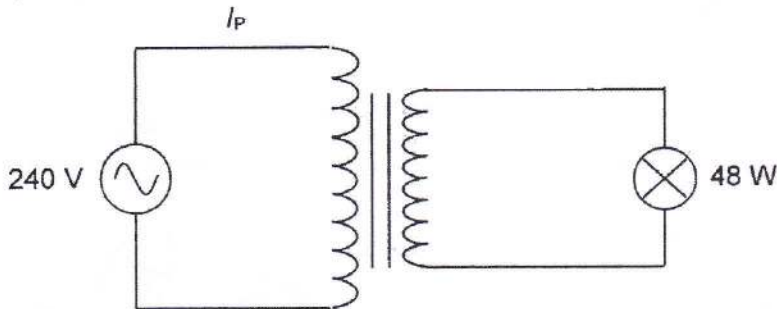

Diagram
Rajah

What happens to the galvanometer's pointer if the copper rod is moved upwards?
 Apakah yang berlaku kepada jarum galvanometer jika rod kuprum itu digerakkan ke atas?

- A No change
Tiada perubahan
- B Deflect to the right
Terpesong ke kanan
- C Deflect to the left
Terpesong ke kiri
- D Deflect to the right and to the left
Terpesong ke kanan dan ke kiri

39. Diagram shows an ideal transformer used to light up a bulb at normal brightness.
 Rajah menunjukkan sebuah transformer unggul digunakan untuk menyalakan satu lampu pada kecerahan normal.



What is the current I_p ?
 Berapakah arus I_p ?

- A 0.2 A
 - B 1.2 A
 - C 5.0 A
 - D 8.0 A
40. Alternating current at very high voltage is used for long distance transmission of electrical energy so as to
 Arus ulang alik bervoltan tinggi digunakan untuk penghantaran tenaga elektrik jarak jauh supaya dapat
- A supply more power to the users.
membekalkan lebih kuasa kepada pengguna.
 - B increase the current in the transmission cable.
menambahkan arus di dalam kabel penghantaran.
 - C reduce power loss during transmission.
mengurangkan kehilangan kuasa semasa penghantaran.
 - D reduce the resistance of the cable.
mengurangkan rintangan kabel.

41. Diagram shows the symbol of a transistor. What are the names of the terminal P, Q and R?
Rajah menunjukkan simbol bagi satu transistor. Apakah nama bagi terminal P, Q dan R?

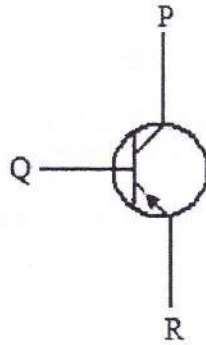

	P	Q	R
A	Collector <i>Pengumpul</i>	Base <i>Papak</i>	Emitter <i>Pengeluar</i>
B	Collector <i>Pengumpul</i>	Emitter <i>Pengeluar</i>	Base <i>Tapak</i>
C	Base <i>Tapak</i>	Collector <i>Pengumpul</i>	Emitter <i>Pengeluar</i>
D	Emitter <i>Pengeluar</i>	Base <i>Tapak</i>	Collector <i>Pengumpul</i>

42. Which of the following circuits does **not** light up the bulb?
*Antara litar berikut, yang manakah **tidak** menyalakan mentol?*

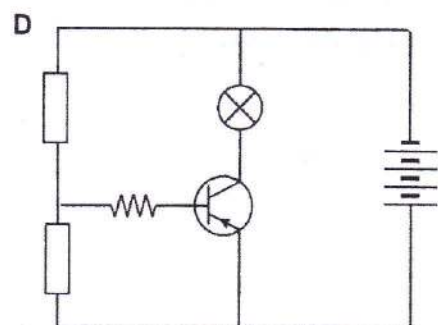
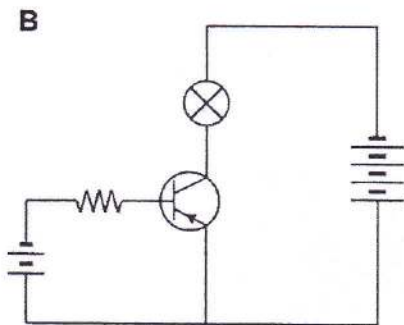
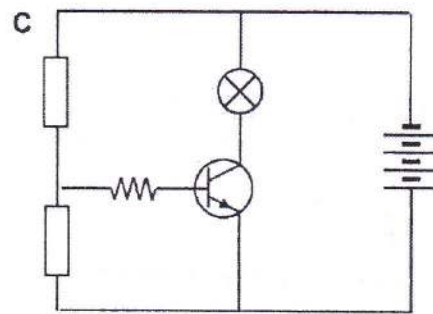
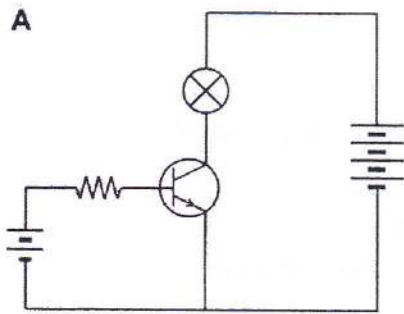

43. Which of the following is true regarding cathode rays?
 Antara berikut yang manakah benar tentang sinar katod?

- A It is positively charged.
 Ia bercas positive.
- B It has same characteristics as beta rays.
 Ia mempunyai sifat yang sama seperti sinar beta.
- C It travels at the same speed as gamma rays.
 Ia merambat pada laju sama dengan sinar gamma.
- D It deflects towards south pole of a magnetic bar.
 Ia terpesong ke kutub selatan suatu bar magnet.

44. Diagram shows a circuit containing two identical bulbs R and S.
 Rajah menunjukkan satu litar mengandungi dua mentol serupa R dan S.

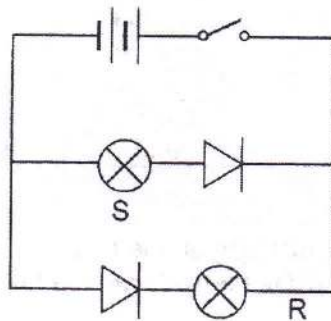

What happens to the bulbs when the switch is on?
 Apakah yang berlaku kepada mentol-mentol itu apabila suis dihidupkan?

- | | Bulb R
Mentol R | Bulb S
Mentol S |
|---|----------------------------------|----------------------------------|
| A | Light off / Tidak menyala | Light off / Tidak menyala |
| B | Light off / Tidak menyala | Light up / Menyala |
| C | Light up / Menyala | Light off / Tidak menyala |
| D | Light up / Menyala | Light up / Menyala |

45. Diagram shows a logic gate circuit which has two inputs, X and Y.
Rajah menunjukkan satu litar get logik yang mempunyai dua input, X dan Y.

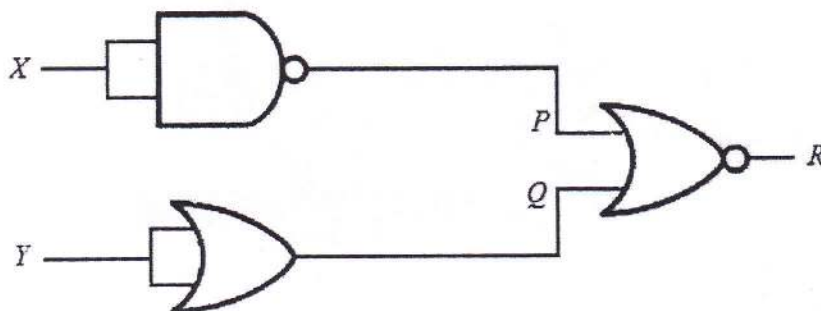

If the logic state of X is 0 and the logic state of Y is 1, what are the logic states at P, Q and R?

Jika keadaan logik X ialah 0 dan keadaan logik Y ialah 1, apakah keadaan logik bagi P, Q dan R?

	P	Q	R
A	0	0	1
B	0	1	1
C	1	1	0
D	1	0	1

46. The equation below represents a nuclear reaction .
Persamaan di bawah mewakili satu tindak balas nuklear

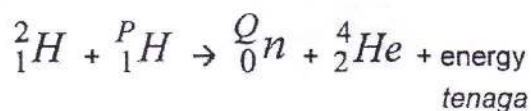

In the nuclear reaction, the values of P and Q are
Dalam tindak balas nuklear itu, nilai-nilai P dan Q adalah

	P	Q
A	3	1
B	2	1
C	4	2
D	3	2

47. Which of the following is the most appropriate radioisotope substance to be used as a medical tracer to detect a tumor?

Antara berikut yang manakah bahan radioisotop yang paling sesuai untuk digunakan sebagai penyurih untuk mengesan tumor?

	Isotope <i>Isotop</i>	Type of emission <i>Jenis pancaran</i>	Half life <i>Separuh Hayat</i>
A	Radon-222 <i>Radon-222</i>	α	3.8 days <i>3.8 hari</i>
B	Sulfur-35 <i>Sulfur-35</i>	β	97 days <i>97 hari</i>
C	Cobalt-60 <i>Cobalt-60</i>	γ	5.3 years <i>5.3 tahun</i>
D	Technitium -99 <i>Technitium-99</i>	γ	6 hours <i>6 jam</i>

48. The graph shows the decay curve of a radioactive material .
Graf menunjukkan lengkungan penyusutan suatu bahan radioaktif.

Activity / counts per minute
Aktiviti/ bilangan per minit

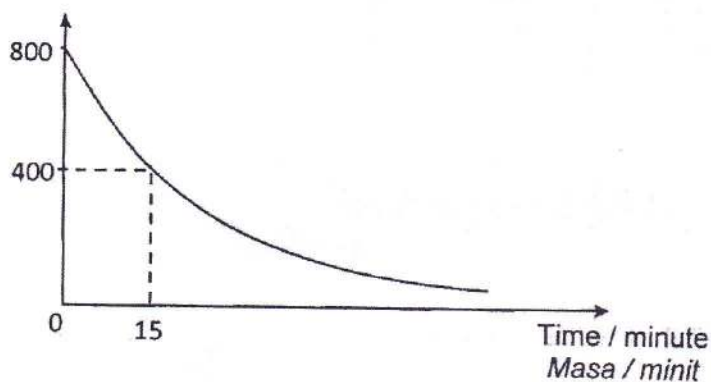

If the initial activity of the radioactive material is 800 counts per minute , what is the activity after 1 hour ?

Jika aktiviti awal bahan radioaktif itu ialah 800 bilangan per minit, berapakah aktiviti nya selepas 1 jam?

- A 50
- B 100
- C 200
- D 400

49. In a nuclear reactor, moderator is used to
Dalam sebuah reaktor nuklear, moderator digunakan untuk
- A absorb slow neutrons
menyerap neutron berhalaju rendah
 - B slow down the fast neutrons
memperlahankan neutron berhalaju tinggi
 - C drive the steam turbine to generate electricity
memacu turbin stim bagi menjana kuasa elektrik
 - D absorb radioactive emissions from the core of the reactor
menyerap pancaran radioaktif daripada teras reaktor
50. Diagram shows an arrangement of apparatus to determine the types of radioactive rays.
Rajah menunjukkan susunan radas untuk menentukan jenis sinaran radioaktif.

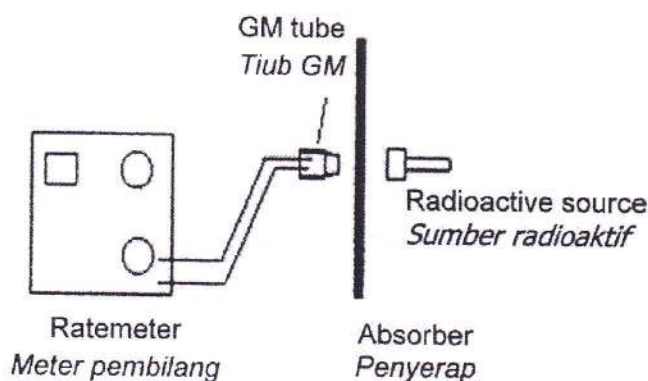

The result obtained as below:
Keputusan berikut diperolehi:

Absorbers <i>penyerap</i>	Counts per minute <i>Bilangan per minit</i>
Nothing <i>Tiada</i>	250
A piece of paper <i>Sehelai kertas</i>	248
Aluminium foil <i>Kerajang aluminium</i>	50
Lead block <i>Bongkah pumblum</i>	49

As the conclusion, this radioactive source emits
Sebagai kesimpulannya, sumber radioaktif tersebut memancarkan

- A α particles only
- B β particles only
- C α particles and γ rays
- D α particles, β particles and γ rays